



DC(M)24-(44,88) Series — Installation Instructions

09/25/15

Applications

The DC(M)24-44,88 Series Actuators are Non-Spring Return Electric Actuators that operate on AC 24 V power, floating control, direct-coupled, actuators.

Features

- Compact, lightweight design
- Manual override
- Standard and plenum models available
- Feedback potentiometer models available
- cUL and UL listed, CE certified
- Independently adjustable dual auxiliary switches available

Actuator Components

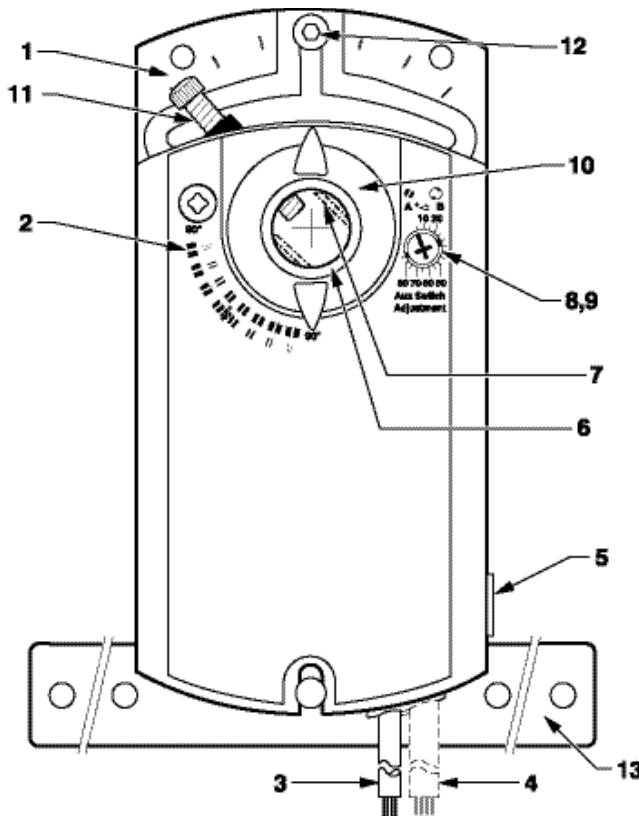

Legend

1. Base plate
2. Positioning scale for angle of rotation
3. Connection cables
4. Connection cables
5. Manual override
6. Coupling bushing
7. Factory installed 1/2-inch guide
8. Auxiliary switch A
9. Auxiliary switch B
10. Position indicator
11. Adjustment lever with locking screw (4 mm hex)
12. Set screw for mechanical range stop (4 mm hex)
13. Mounting bracket

Figure 11. Parts of the Actuator.

Operation

A floating control signal controls the damper actuator. The actuator's angle of rotation is proportional to the length of time the signal is applied. A 24 Vac control signal to wires 1 and 6 (G-Y1) causes the actuator coupling to rotate clockwise. A 24 Vac control signal to wires 1 and 7 (G-Y2) causes the actuator coupling to rotate counterclockwise.

To reverse the direction of rotation, the wires 6 and 7 (Y1 and Y2) can be interchanged.

In the event of a power failure or with no control voltage, the damper actuator holds its position.

Life Expectancy

An improperly tuned loop will cause excessive repositioning that will shorten the life of the actuator.



Auxiliary Switches

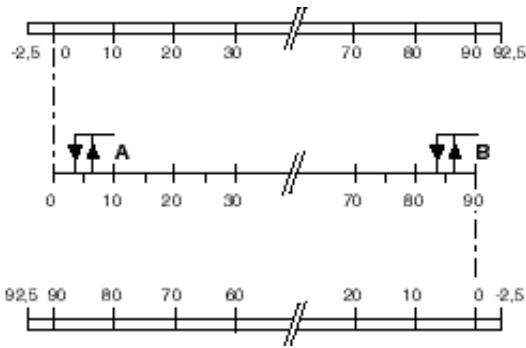

Actuator Scale: Clockwise

Adjustment range for Switches A and B
Setting interval: 5° Switching hysteresis: 2°

Actuator Scale: Counterclockwise

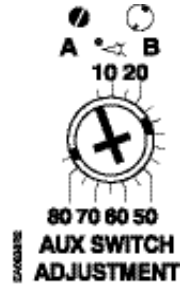

Figure 14. Adjustable Switching Values for the Dual Auxiliary Switches.

NOTE: The auxiliary switch setting shafts rotate with the actuator. The scale is valid only when the actuator is in the "0" position on clockwise motion. Use the long arm of the † to point to the position of switch A. Use the narrower tab on the red ring to point to the position of switch B.

Mounting and Installation

You must place the actuator on the damper shaft so that the front of the actuator is accessible. The label is on the front side.

The minimum damper drive shaft length is 3/4-inch (20 mm).

- A mounting bracket is included with the actuator.
- Observe the service envelope around the actuator as shown in XFigure 25X.
- Detailed mounting instructions are included with each actuator.



Figure 15. Damper Shaft Sizes.

NOTE: For all damper shafts with the exception of the 1/2-inch round shaft: Remove 1/2-inch Ø guide before installation.

Manual Override

To move the damper blades and lock the position with no power present:

1. Slide the red manual override knob toward the back of the actuator.
2. Make adjustments to the damper position.
3. Slide the red manual override knob toward the front of the actuator.

Once power is restored, the actuator returns to automated control.

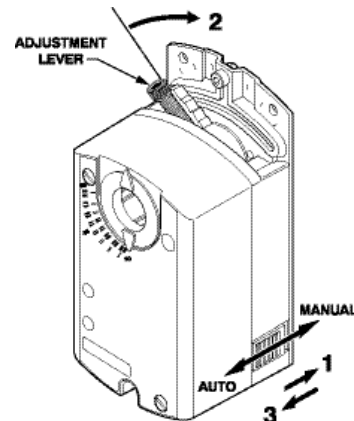

Figure 16. Manual Override.



Mechanical Range Adjustment

1. Loosen the stop set screw.
2. Move the screw along the track to the desired position, and fasten it in place.

Wiring

All wiring must conform to NEC and local codes and regulations.

Use earth ground isolating step-down Class 2 transformers. Do not use autotransformers.

The sum of the VA ratings of all actuators and all other components powered by one transformer must not exceed the rating of the transformer. It is recommended that one transformer power no more than ten actuators.

CAUTION:

Do not wire different types of actuators in parallel.

WARNINGS:

All six outputs of the dual auxiliary switch (A and B) must only be connected to:

- Class 2 voltage (UL/CSA).
- Separated Extra-Low Voltage (SELV) or Protective Extra Low Voltage (PELV) (according to HD384-4-41) for installations requiring conformance. You must use a certified plenum rated actuator.

Installations requiring Conformance:

- All wiring for CE certified actuators must be "Separated Extra Low Voltage" (SELV) or "Protective Extra Low Voltage" (PELV) per HD384-4-41.

- Use safety-isolating transformers (Class III transformer) per EN61558. They must be rated for 100% duty cycle.

- Over current protection for supply lines is maximum 10A.

Direction of Damper Rotation

If the damper blades turn counterclockwise to open (CCW), reverse the 6 (violet) and 7 (orange) wires at the controller.

Time-Out Function

To prolong actuator life, use a controller and/or software that provide a time-out function. This function removes the actuator drive signal after the signal has been on for a predefined time.

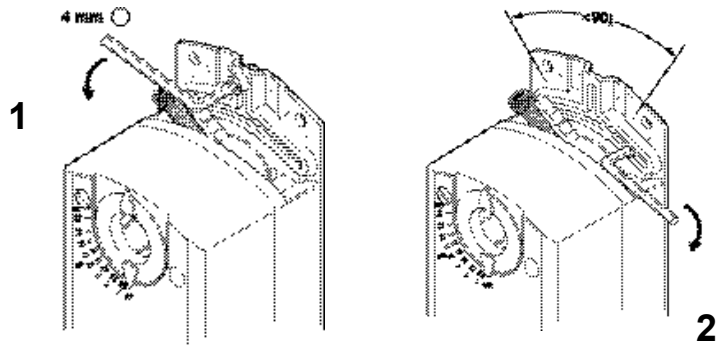
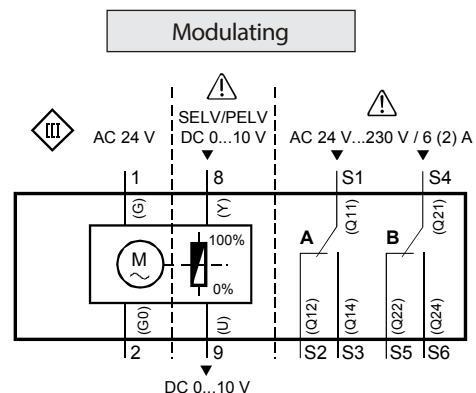
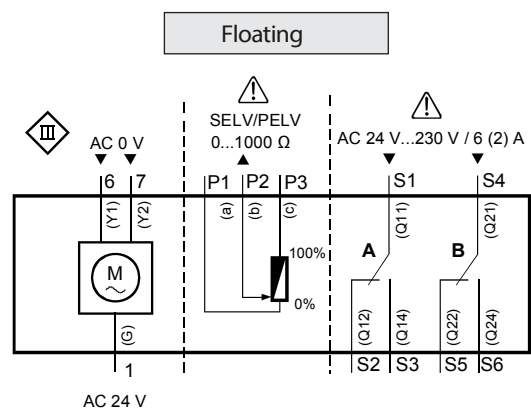

Figure 17. Moving the Mechanical Range Stop.

Cable			Function
No.	Code	Color	
1	G	Red (RD)	AC 24 V Supply (SP)
2	G0	Black (BK)	Neutral (SN)
6	Y1	Violet (VT)	Control Signal Clockwise AC 0 V
7	Y2	Orange (OG)	Control Signal AC 0 V Counterclockwise
8	Y	Grey (GY)	Control signal DC 0..10 V, 0..35 V
9	U	Pink (PK)	Position indication DC 0..10 V
Auxillary Switch - Factory Installed			
S1	Q11	Gray/Red (GY RD)	Switch A Input
S2	Q12	Gray/Blue (GY BU)	Switch A - N.C.
S3	Q14	Gray/Pink (GY PK)	Switch A - N.O.
S4	Q21	Black/Red (BK RD)	Switch B Input
S5	Q22	Black/Blue (BK BU)	Switch B - N.C.
S6	Q24	Black/Pink (BK PK)	Switch B - N.O.





Strain Relief

Securing the wires/cabling will prevent breakage and ensure strong signals. The following is recommended:

1. The open bracket to the right of the actuator terminal strip is the strain relief for the customer provided control wires.
2. Secure the wires to the actuator bracket with a cable tie.

Start-Up/Commissioning

1. Check that the wires are connected correctly.
2. Connect wires 1 (red) and 6 (violet) to a Digital Multimeter (DMM) with the dial set at Vac. Apply a control signal (24 Vac) to wires 1 and 6 to verify that the operating voltage is within range.
3. Connect wires 1 (red) and 7 (orange) to a DMM with the dial set at Vac. Apply a control signal (24 Vac) to wires 1 and 7 to verify that the operating voltage is within range.

Check Operation:

1. Connect wire 1 (red) to the actuator.
2. Apply a control signal (24 Vac) to wires 1 (red) and 6 (violet).
3. Allow the actuator shaft coupling to rotate from 0° to 90°.
4. Stop applying a control signal to wires 1 (red) and 6 (violet).
5. Apply a control signal (24 Vac) to wires 1 (red) and 7 (orange).
6. Allow the actuator shaft coupling to rotate from 90° to 0°.

Check Feedback:

1. Set the DMM dial to ohms.
2. Connect wires P1 and P2 to the DMM. The DMM should indicate a resistive value.
3. Apply a control signal (24 Vac) to wires 1 (red) and 6 (violet). The reading of the DMM should increase.
4. Connect wires P2 and P3 to the DMM. The DMM should indicate a resistive value.
5. Apply a control signal (24 Vac) to wires 1 (red) and 7 (orange). The reading of the DMM should increase.

Check the Auxiliary Switch A:

1. Set the DMM dial to ohms (resistance) or continuity check.
2. Connect wires S1 and S3 to the DMM. The DMM should indicate an open circuit or no resistance.
3. Apply a control signal (24 Vac) to wires 1 (red) and 6 (violet). The DMM should indicate contact closure as the actuator shaft coupling reaches the setting of switch A.
4. Stop applying a control signal to wires 1 (red) and 6 (violet).
5. Connect wires S1 and S2 to the DMM. The DMM should indicate an open circuit or no resistance.
6. Apply a control signal (24 Vac) to wires 1 (red) and 7 (orange). The DMM should indicate contact closure as the actuator shaft coupling reaches the setting of switch A.

Check the Auxiliary Switch B:

1. Set the DMM dial to ohms (resistance) or continuity check.
2. Connect wires S4 and S6 to the DMM. The DMM should indicate an open circuit or no resistance.
3. Apply a control signal (24 Vac) to wires 1 (red) and 6 (violet). The DMM should indicate contact closure as the actuator shaft coupling reaches the setting of switch B.
4. Stop applying a control signal to wires 1 (red) and 6 (violet).
5. Connect wires S4 and S5 to the DMM. The DMM should indicate an open circuit or no resistance.
6. Apply a control signal (24 Vac) to wires 1 (red) and 7 (orange). The DMM should indicate contact closure as the actuator shaft coupling reaches the setting of switch B.

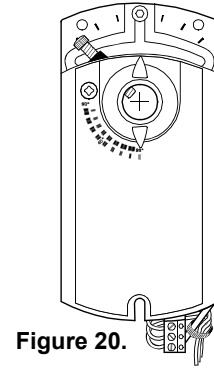

Figure 20.